

INNOVATEST[®]
Advanced Hardness Testing Solutions

NEMESIS 9500™ SERIES



NEMESIS 9500™ Series Universal hardness tester



General information

The NEMESIS 9500™ is the universal hardness tester most suitable for heavy duty testing in the INNOVATEST® standard range of testers. Partly based on the technology of the NEMESIS 9000™. Built for tough environments.

The floor type frame reaches a height of 2 meters and offers a workspace of not less than 650mm height and a throat depth of 400mm from spindle center. Rockwell, Vickers and Brinell, but also pure depth test methods such as H, HVT and HBT are part of the standard test procedures of the NEMESIS 9500™.

3 Models cover a range of test loads either up to 250kgf/2.45kN, 750kgf/7.35kN or 3000kgf/29kN.

The frame of the NEMESIS 9500™ is equipped with a heavy duty motorized spindle, allowing to position the test piece on the required working height. The NEMESIS 9500™ has a descending test head allowing each test piece to be tested on an ergonomic working height. The linear actuator of the NEMESIS 9500™ is equipped with a load cell closed loop system guaranteeing excellent accuracy and a wide range of fast testing procedures.

The test head is equipped with a 6 positions modular turret (indentors and objectives) and an optical zoom video system with 5mp HD camera. High performance embedded micro PC driven automatic and manual indent measurement with automatic filing and storage functions. Refined algorithms for automatic measurement on materials normally less suitable for automatic measurement.

IMPRESSIONS™, FIRMWARE

IMPRESSIONS™ is the advanced user operating system of the NEMESIS 9000™ Series. The software incorporates, manual and automatic measurement for all scales, image editing, file storing, image storing, report printing, turret operation, manual or automatic focusing and many other advanced functions.

The firmware converts to 3 different hardness (and tensile) scales simultaneously. The conversions can be set to material and standard (ISO/ASTM)

The system also controls an (optional) X-Y stage, rotary or inclining table that can be plugged into the standard built-in driver of the tester.

No additional charges, no external devices.

In combination with an X-Y stage the tester offers the option of running case depth hardness programs, pre defined testing patterns and/or other specific or special tasks defined by the user.

All data can be copied or exported in to MS applications like Word, Excel, or a report generator that emails test results directly to your workstation, or server. All data can be accessed over the LAN or WLAN connections.

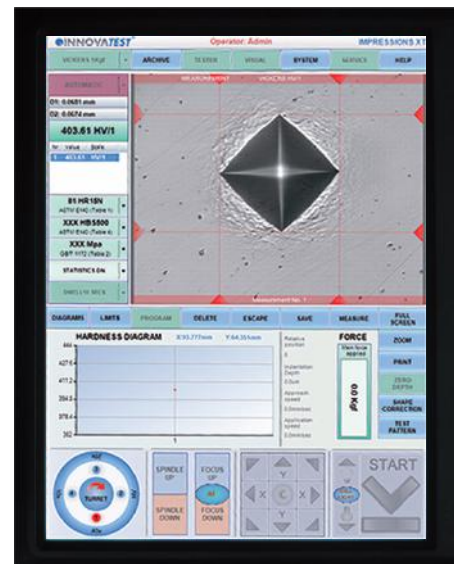

Technical specifications

NEMESIS 9500™	
Hardness scales	Rockwell, Vickers, Brinell, Vickers depth (HVT), Brinell depth (HBT)
Load application	Load cell, force feedback, closed loop system
Load range	1kgf/9.8N - 250kgf/2.45kN, 3kgf/29N - 750kgf/7.35kN, 10kgf/98N - 3000kgf/29kN
Motorized turret	3 indenter positions, 3 objectives positions
Optical system	High definition, 5Mp machine Vision system
Objectives	3 installed for 0.7x - 1000x magnification
Electronic system	High performance embedded micro PC, Windows® 7, 15" full color touch screen, automatic and manual measurement
Standards	Meets or exceeds, ISO, ASTM, JIS (Nadcap) standards
Test loads	1kgf/9.8N, 2kgf/19N, 2.5kgf/24N, 3kgf/29N, 4kgf/39.2N, 5kgf/49N, 10kgf/98N, 15kgf/147.1N, 15.625kgf/153N, 20kgf/196N, 30kgf/294.2N, 31.25kgf/306N, 45kgf/441N, 50kgf/490N, 60kgf/588.4N, 62.5kgf/512N, 100kgf/980.7N, 125kgf/1225N, 150kgf/1471N, 187.5kgf/1838N, 250kgf/2.45kN, 750kgf/7.35kN, 1000kgf/9.8kN, 1500kgf/14.7kN, 3000kgf/29kN
Rockwell test scales	A, B, C, D, E, F, G, H, K, L, M, P, R, S, V
Vickers test range	1kgf/9.8N - 120kgf/1176N (depending on model) HV: 1kgf/9.8N, 2kgf/19N, 3kgf/29N, 4kgf/39.2N, 5kgf/49N, 10kgf/98N, 20kgf/196N, 30kgf/294.2N, 50kgf/490N, 100kgf/980.7N, 120kgf/1176N HVT: 50kgf/490N, 100kgf/980.7N
Brinell test range	1kgf/9.8N - 3000kgf/29kN (depending on model) HB1: 1kgf/9.8N, 2.5kgf/24N, 5kgf/49N, 10kgf/98N, 30kgf/294.2N HB2.5: 6.25kgf/62N, 15.625kgf/153N, 31.25kgf/306N, 62.5kgf/612N, 187.5kgf/1838N HB5: 25kgf/245N, 62.5kgf/612N, 125kgf/1225N, 250kgf/2.45kN, 750kgf/7.35kN HB10: 100kgf/980.7N, 250kgf/2.45kN, 500kgf/4.9kN, 750kgf/7.35kN, 1000kgf/9.8kN, 1500kgf/14.7kN, 3000kgf/29kN HBT: 5kgf/49N, 250kgf/2.45kN
Test cycles	Automatic and Manual
Force control	2 - 99 seconds
Connectivity	USB-2, Blue tooth, WLAN, LAN
Workpiece accommodation	Vertical capacity 650mm, Horizontal capacity 400mm (from center-line)
Operating temperature	10°C to 35°C, non-condensing
Machine dimensions	540mm x 1000mm x 2120mm (WxDxH)
Machine weight	1100kg
Power supply	100V AC to 240V AC, 50Hz/60Hz, 3A, single phase

Standard delivery

- Large testing table 650 x 500mm
- Motorized turret with 6 positions
- Objectives for 0.7x - 1000x magnification
- Built-in 3 axis support driver
- Toolset
- Wireless mouse and keyboard
- Power cable
- INNOVATEST® certificate
- Installation and user manual

Optional accessories

- Certified indentors (ASTM, DIN, ISO)
- Certified reference hardness blocks (ASTM, DIN, ISO)
- V-anvil, hardened, ø80mm
- V-anvil, hardened, ø120mm
- Testing table, ø235mm
- Indentor, Vickers, long
- Other testing tables and X-Y stages
- Built-in 5 axis support driver
- Precision vices, V-blocks and special clamps



Order details

NEMESIS 9501™

Heavy duty video based Universal hardness tester,
test forces 1kgf/9.8N to 250kgf/2.45kN

NEMESIS 9502™

Heavy duty video based Universal hardness tester,
test forces 3kgf/29N to 750kgf/7.35kN

NEMESIS 9503™

Heavy duty video based Universal hardness tester,
test forces 10kgf/98N to 3000kgf/29kN

Technical specifications

All dimensions are in mm

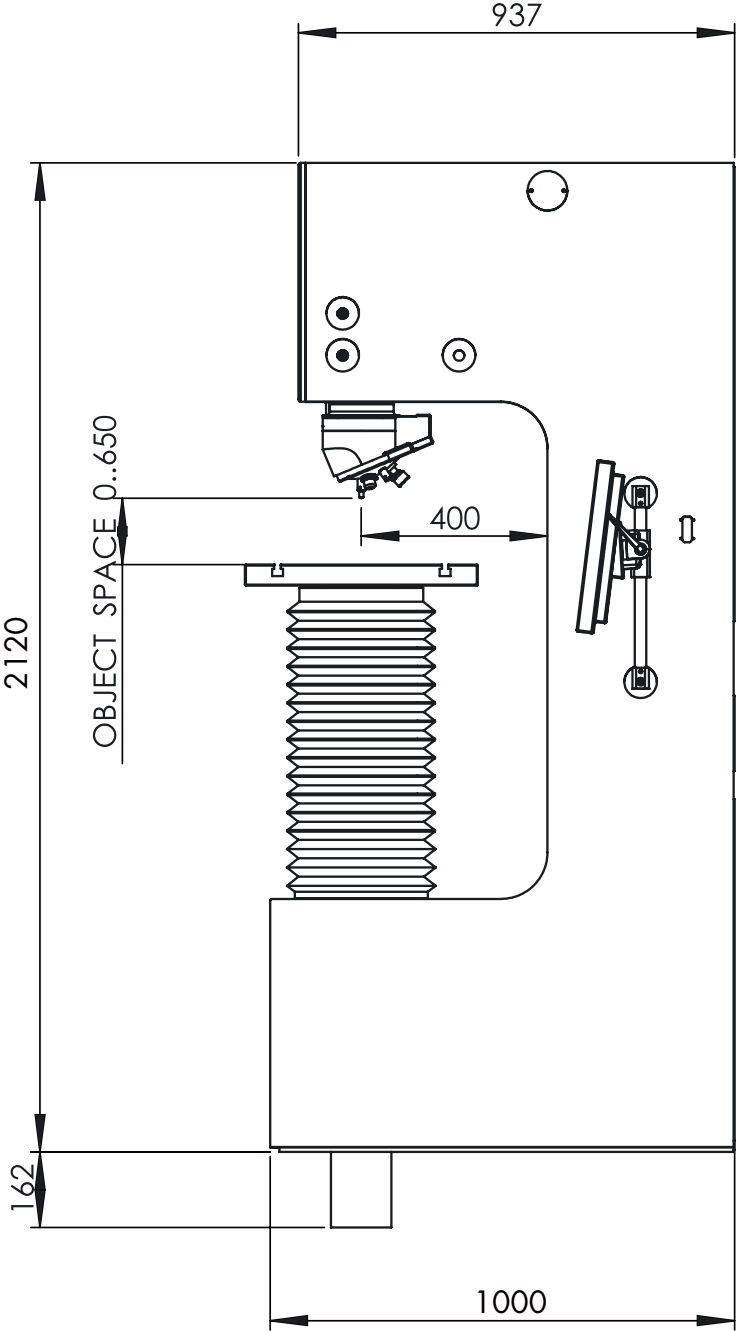

All dimensions are in mm

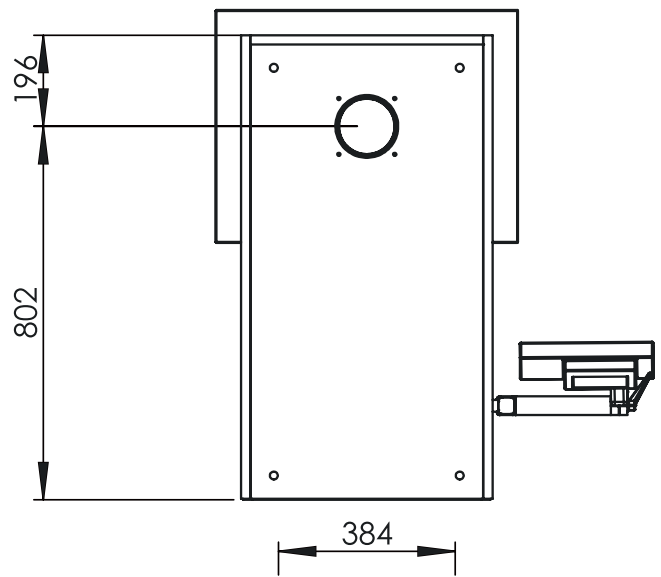
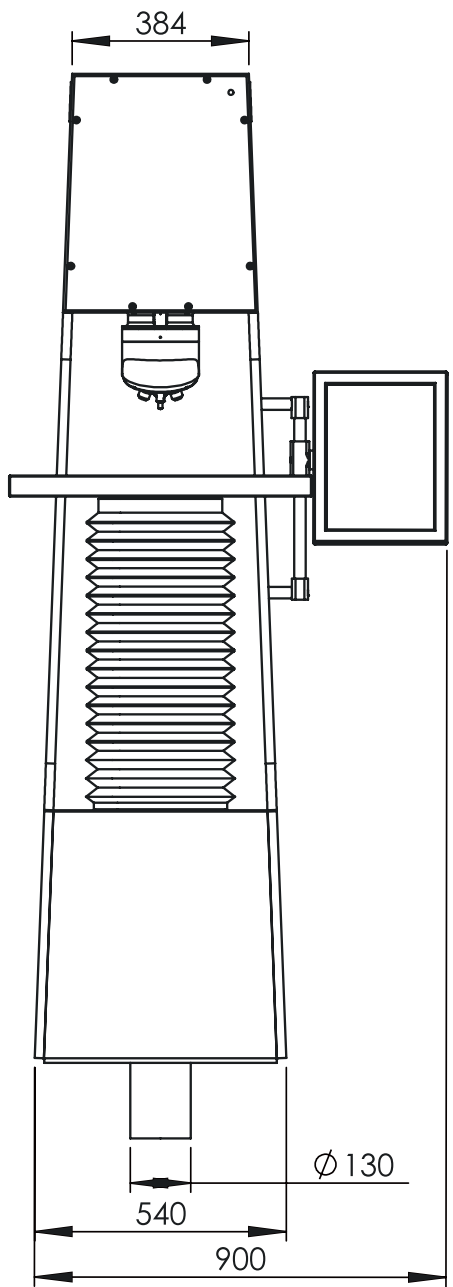

Represented by:

CORPORATE HEAD OFFICE

INNOVATEST Europe BV
MANUFACTURING, DISTRIBUTION & SERVICE

Borgharenweg 140
6222 AA Maastricht (The Netherlands)
Phone: +31 43 3520060
Fax: +31 43 3631168
E-mail: info@innovatest-europe.com
Website: www.innovatest-europe.com

INNOVATEST Shanghai Co., Ltd.
DISTRIBUTION, SALES & SERVICE

Building 2, No.123, 1165 Nong Jindu Road,
South Metropolis Industrial Park
Minhang District, Shanghai, P.R. China
Zip code: 201108
Phone: +86 21 60906200
Fax: +86 21 60912595
E-mail: info@innovatest-shanghai.com
Website: www.innovatest-shanghai.com

INNOVATEST SOUTH EAST ASIA
CUSTOMER SUPPORT CENTER

(c/o LMS Technologies Pte Ltd)
20 Sin Ming Lane #05-58 Midview City
Singapore 573 968
Phone: +65 6451 1123
Fax: +65 6452 1011
E-mail: info@lmstech.com.sg
Website: www.lmsscientific.com

Changes in products and/or product specifications can emerge due to new technologies and continuous development. We reserve the right to change or modify specifications of products without prior notice. We recommend you to contact our sales office for up-to-date information. © All rights reserved